

(12) **United States Patent**
Yaniv et al.

(10) **Patent No.:** US 6,552,563 B1
(45) **Date of Patent:** Apr. 22, 2003

- (54) **DISPLAY PANEL TEST DEVICE** 5,329,423 A 7/1994 Scholz 361/760
- 5,342,207 A 8/1994 Sobhani 439/74
- (75) **Inventors:** **Zvi Yaniv**, Bloomfield Hills, MI (US); 5,378,982 A * 1/1995 Feigenbaum et al. 324/770
- Nalin Kumar**, Austin, TX (US); 5,415,555 A 5/1995 Sobhani 439/74
- Nathan Potter**, Austin, TX (US) 5,434,513 A 7/1995 Fujii et al. 324/765
- 5,489,804 A 2/1996 Pasch 257/778
- (73) **Assignee:** **SI Diamond Technology, Inc.**, Austin, TX (US) 5,508,228 A 4/1996 Nolan et al. 437/183
- 5,764,209 A * 6/1998 Hawthorne et al. 345/87

(*) **Notice:** Subject to any disclaimer, the term of this patent is extended or adjusted under 35 U.S.C. 154(b) by 1046 days.

* cited by examiner

Primary Examiner—Kamand Cuneo
Assistant Examiner—Russell M. Kobert
(74) *Attorney, Agent, or Firm*—Kelly K. Kordzik; Winstead Sechrest & Minick P.C.

(21) **Appl. No.:** 08/748,893

(22) **Filed:** Nov. 14, 1996

- (51) **Int. Cl.⁷** **G01R 31/00**
- (52) **U.S. Cl.** **324/770; 324/754**
- (58) **Field of Search** 324/757, 770, 324/754, 755; 361/749, 750, 751, 771, 767, 768; 174/254, 260, 267

(57) **ABSTRACT**

A device for testing flat panel displays includes an interface having compliant bumps mounted thereon, which make electrical contact with pads on the display panel. The interface may have a hole formed therein for allowing the passage of light therethrough when the interface is mounted on the display panel. The compliant bumps ensure that all of the bumps make sufficient electrical contact with the pads.

(56) **References Cited**

U.S. PATENT DOCUMENTS

3,832,632 A * 8/1974 Ardezzone 324/756

22 Claims, 3 Drawing Sheets

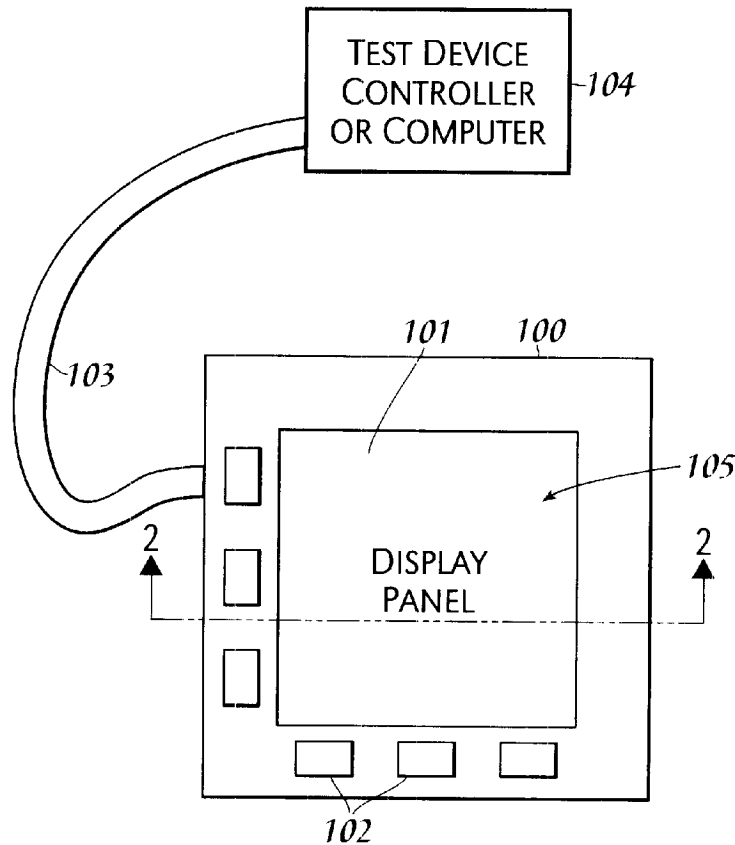

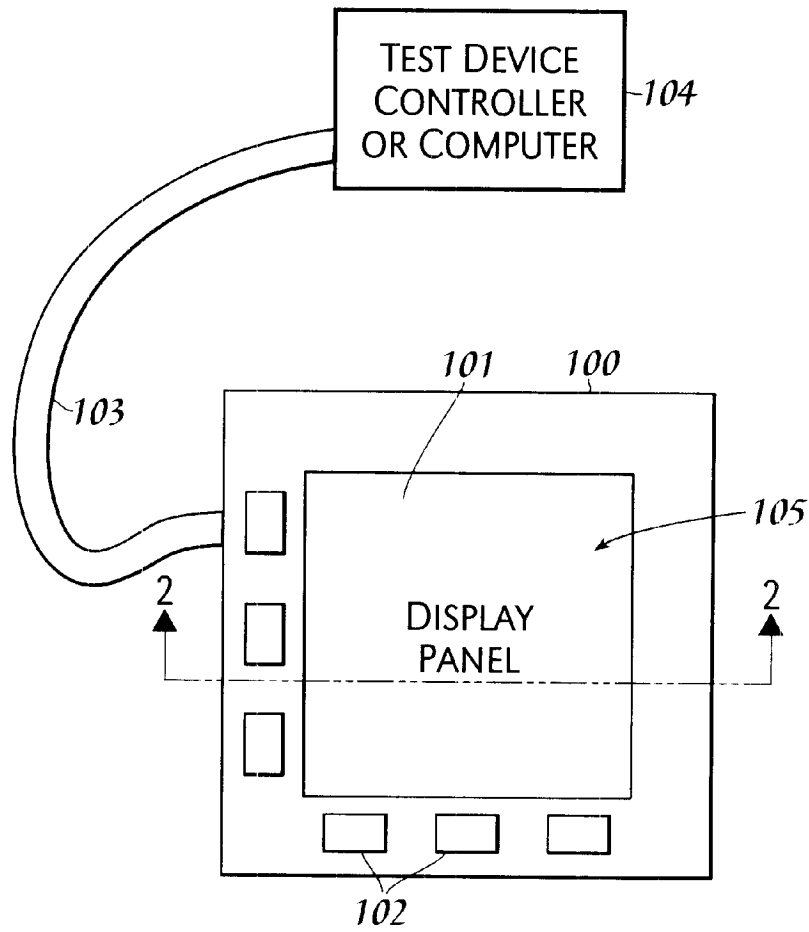

Fig. 1

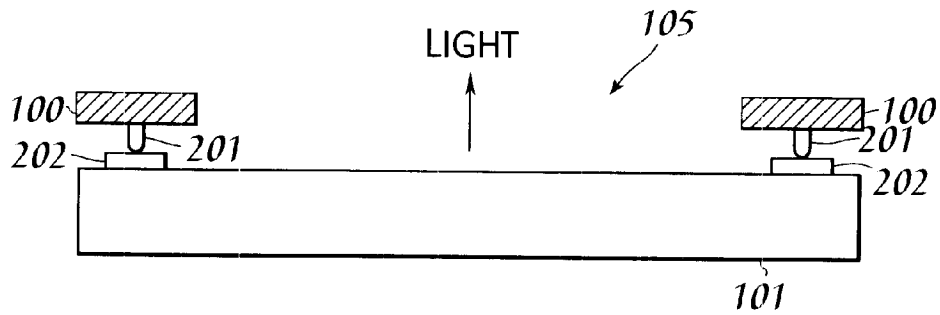

Fig. 2

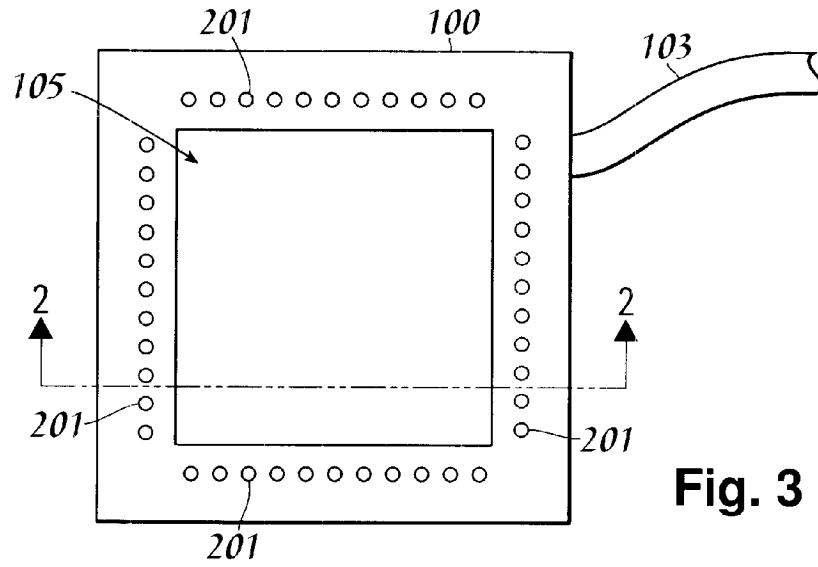

Fig. 3

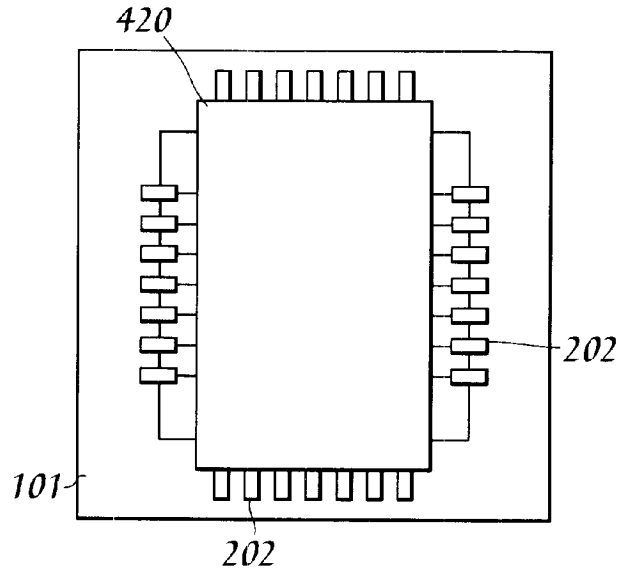

Fig. 4

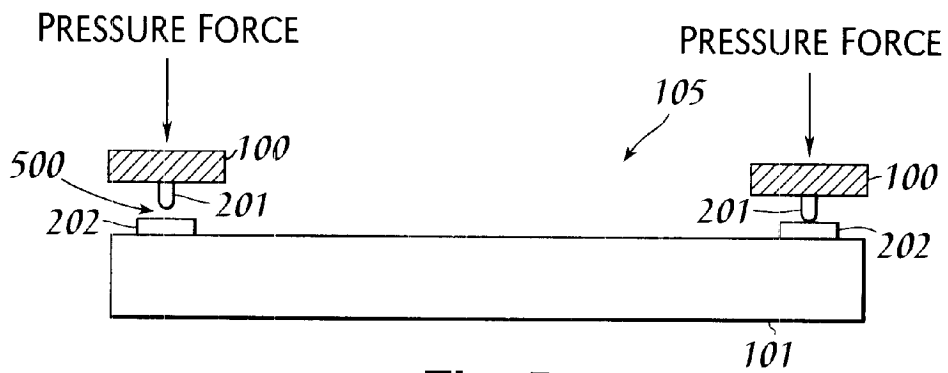

Fig. 5

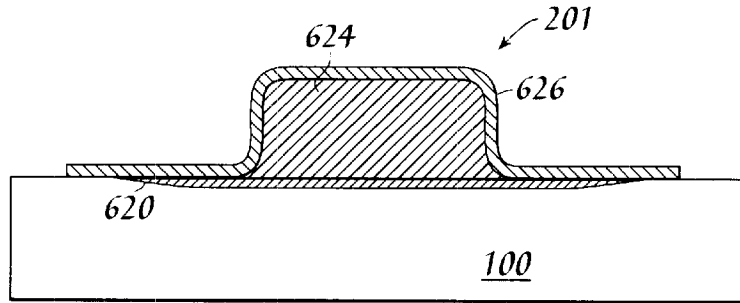

Fig. 6

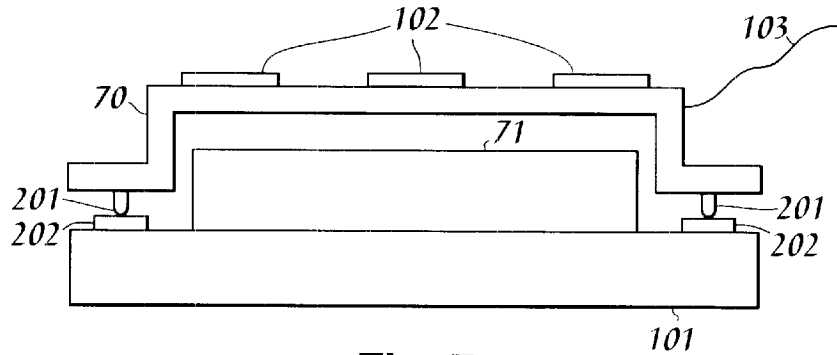

Fig. 7

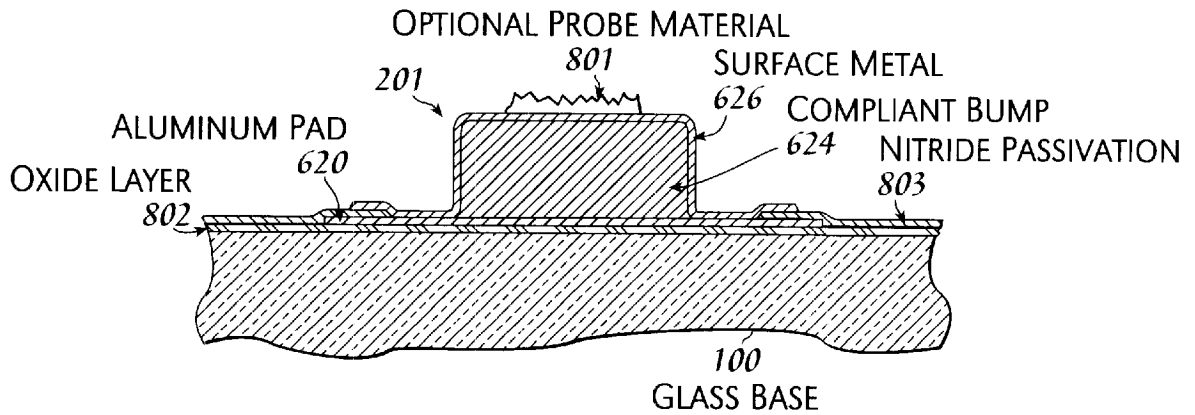

Fig. 8

DISPLAY PANEL TEST DEVICE

TECHNICAL FIELD

The present invention relates in general to displays, and in particular, to a device for testing display panels.

BACKGROUND INFORMATION

Flat panel displays are a growth industry with projections for even greater growth into the next century. Such flat panel displays are and will be manufactured using various technologies, such as liquid crystal displays ("LCDs"), field emission displays ("FEDs"), plasma displays, displays using one or more of the aforementioned technologies, etc.

Regardless of the display technology utilized, there are typically numerous electrical contact pads located around the periphery of the display panel in order to provide an electrical path to each of the various pixel locations within the display panel. For example, in a matrix-addressable display panel, there will be several rows and columns of intersecting electrical pathways for selectively addressing the individual pixels within the display panel. Each of these rows and columns are accessible externally by corresponding pad locations. An example of such pads is illustrated in FIG. 4, and further described in U.S. Pat. No. 5,449,970, which is hereby incorporated by reference herein, which shows panel 101 with pixels 420 (not shown in detail) addressed via pads 202.

During various manufacturing stages, and upon completion of the manufacturing of the display panel, various tests of the display panel are often desired to ensure the quality of the manufacturing process and the resulting end quality of the display panel. To perform such tests, there needs to be some type of interface for coupling the individual pads on the display panel to test circuitry. As a result, there is a need in the art for an improved test interface for testing of flat panel display panels.

SUMMARY OF THE INVENTION

The foregoing need is satisfied by the present invention, which includes an interface having electrical paths adaptable for coupling to display test circuitry, wherein the interface includes one or more compliant bumps mounted on the interface and connected to the electrical paths, wherein the compliant bumps are adaptable for making contact with the pads on the display panel.

The interface may be constructed of a printed circuit board ("PCB") having electrical paths embedded thereon making contact with each one of the compliant bumps. Furthermore, the interface may have mounted thereon driver circuitry for driving the individual pixels of the display panel. The driver circuitry may be coupled to a test device controller or a computer by a ribbon cable.

The interface may also be in the form of a ring having a hole formed therein so that when the interface is mounted on the display panel, light emitted from the display panel can pass through the hole and be observed.

An advantage in incorporating compliant bumps is that sufficient electrical connection is made between each one of the pads and the compliant bumps by using pressure to adjoin the interface and the display panel despite the fact that such sufficient electrical connection may not exist at one or more interface locations between the bumps and the pads during initial contact between the interface and the display panel.

Another advantage of the present invention is that the compliant polymer that forms part of the compliant bump provides a mechanism that compensates for warp or non-planarities in the PCB substrate as well as for pad height non-uniformities. Better bump height uniformity may be achieved using the present invention than is possible with conventional techniques that electroplate solid metal bumps.

Compliant bumps also respond compliantly over a larger range of displacements than do metals. These factors allow bonding forces to be lower than with solid metal bumps. This is because there is no need for the excessive bonding forces used to plastically deform metal bumps to correct for bump non-uniformities. The present invention, accordingly permits use of a wider range of bonding perimeters while ensuring electrical conductivity between the testing interface and the display panel.

The foregoing has outlined rather broadly the features and technical advantages of the present invention in order that the detailed description of the invention that follows may be better understood. Additional features and advantages of the invention will be described hereinafter which form the subject of the claims of the invention.

BRIEF DESCRIPTION OF THE DRAWING

For a more complete understanding of the present invention, and the advantages thereof, reference is now made to the following descriptions taken in conjunction with the accompanying drawings, in which:

FIG. 1 illustrates an apparatus for testing a display panel in accordance with the present invention;

FIG. 2 illustrates a cross-sectional view of the interface in accordance with the present invention;

FIG. 3 illustrates a bottom view of the interface of the present invention showing the compliant bumps;

FIG. 4 illustrates a display panel to be tested;

FIG. 5 illustrates mounting of the present invention on the display panel where during initial contact not every bump is making sufficient contact with the pads of the display panel;

FIG. 6 illustrates further detail of a compliant bump;

FIG. 7 illustrates an alternative embodiment of the present invention; and

FIG. 8 illustrates addition of an optional probing material to a compliant bump.

DETAILED DESCRIPTION

In the following description, numerous specific details are set forth to provide a thorough understanding of the present invention. However, it will be obvious to those skilled in the art that the present invention may be practiced without such specific details. In other instances, well-known circuits have been shown in block diagram form in order not to obscure the present invention in unnecessary detail. For the most part, details concerning timing considerations and the like have been omitted inasmuch as such details are not necessary to obtain a complete understanding of the present invention and are within the skills of persons of ordinary skill in the relevant art.

Refer now to the drawings wherein depicted elements are not necessarily shown to scale and wherein like or similar elements are designated by the same reference numeral through the several views.

Referring to FIG. 1, there is illustrated a top view of interface 100 mounted on display panel 105 for testing. As noted above, display panel 105 may be in one of various

stages of manufacture. Light emitted from display panel **105** may be observed through hole **105** within interface **100**.

Interface **100** may be comprised of a PCB or other equivalent material. Shown are several driver chips **102** mounted on two sides of interface **100**. Optionally, driver chips **102** may be mounted along the entire periphery of interface **100**, especially in the instance when pads (not shown) on display panel **105** are located along the entire periphery of display panel **101**. Coupling of driver chips **102** to a test device controller or computer **104** is done by ribbon cable **103** or an equivalent structure. One skilled in the art will be able to make the individual connections between ribbon cable **103** and driver chips **102**.

The driver chips provide for in-line functional testing of a display using essentially the same electronic circuitry that will be used to drive the display during use. Furthermore, chips **102** may include circuitry for testing other aspects of the display during any stage of manufacturing of the display. For example, testing of the lines (which may be aluminum) may be performed to determine if the circuit lines to the display matrix are good. Additionally, chips **102** may include circuitry for measuring the resistance of the lines.

Referring next to FIG. **3**, there is illustrated the underside of interface **100** showing individual compliant bumps **201** located along the periphery of interface **100**. Shown are compliant bumps **201** located on all four sides of interface **100**. However, in an instance where pads on the display panels are located on only two sides, interface **100** may only include compliant bumps **201** on two corresponding sides of interface **100**.

Note, interface **100** is shown in the form of a square with a hole **105** formed therein, but may comprise any shape, as long as compliant bumps **201** are located thereon so as to match the structure of the pads located on the display panel **101**.

Referring next to FIG. **2**, there is illustrated a cross-sectional view of interface **100**. Display panel **101**, has pads **202** located thereon for accessing individual pixels (not shown) within display panel **101**. When interface **100** is mounted onto display panel **101**, compliant bumps **201** make contact with pads **202** so that there is an electrical connection therebetween for running the various test operations.

Referring next to FIG. **5**, there is illustrated an instance in time wherein interface **100** is making initial contact with display panel **101**. At this instance in time, there is gap **500** between one or more of compliant bumps **201** and pads **202** while other compliant bumps **201** are making sufficient contact with corresponding pads **202**. This may occur due to imperfections within the manufacture of interface **100** so that it is not completely planar, or in the manufacture of compliant bumps **201** and/or in the manufacture of pads **202** so that they do not have coplanar contact surfaces relative to each other.

Display panel **101** may comprise any display technology, such as FED or LCD. As shown, in order to ensure that all compliant bumps **201** make sufficient electrical contact with pads **202**, a pressure force may be applied onto interface **100** into display panel **101**. As discussed within U.S. Pat. No. 5,508,228, which is hereby incorporated by reference herein, compliant bumps **201** permit such a pressing force to be performed with little or no stressing of interface **100** or display panel **101**, since the compliant bumps **201** already in contact with pads **202** may be compressed slightly so that other compliant bumps **201** are able to eventually make contact with pads **202**, as shown in FIG. **2**.

Referring next to FIG. **6**, there is illustrated further detail of compliant bump **201** in a cross-sectional view. On interface **100** is wire bond pad **620**. Wire bond pad **620** is a portion of the electrical pads coupling compliant bumps **201** to driver chips **102**. Polymer bump **624** attaches to wire bond pad **620**. Gold metalization layer **626** covers both polymer bump **624** and may cover at least a portion of bond pad **620**. For a further discussion of compliant bumps, please refer to U.S. Pat. No. 5,508,228, which also discusses the advantages of using compliant bump technology.

Referring next to FIG. **7**, there is illustrated an alternative embodiment of the present invention which shows the display at an advanced stage during the manufacturing process where color filter **71** has been mounted onto display panel **101**. Interface **100** has been modified to be interface **70** which is physically able to mount over color filter **71** in order to perform the testing process as described above.

An advantage of using compliant bump technology with such a testing device is that the testing interface has a longer lifetime because of the ease of stress brought about by the compressibility of the compliant bumps. Furthermore, the sometimes delicate nature of flat panel displays is also protected by the use of the compliant bumps on the interface.

Referring next to FIG. **8**, there is illustrated an alternative embodiment of the present invention where compliant bump **201** is modified to add a thin film of a sharp probing material, which aids in making a low resistive contact with pads **202** by "breaking through" any oxide layer for example. The probing material may comprise a diamond grit mixed with a conductive epoxy or a metal paste deposited on the surface of compliant bump using well-known techniques. FIG. **8** also shows an oxide layer **802** and nitride passivation **803**.

Although the present invention and its advantages have been described in detail, it should be understood that various changes, substitutions and alterations can be made herein without departing from the spirit and scope of the invention as defined by the appended claims.

What is claimed is:

1. An apparatus adaptable for testing an electric device comprising:
 - an interface having electrical paths adaptable for coupling to display test circuitry; and
 - one or more compliant bumps mounted on said interface and connected to said electrical paths, wherein said one or more compliant bumps are adaptable for making contact with pads on said electric device wherein said electric device is a display panel.
2. The apparatus as recited in claim **1** wherein said display test circuitry includes driver electronics mounted on a PCB and coupled to said electrical paths.
3. The apparatus as recited in claim **1** wherein said interface has a ring structure forming a hole in said interface to permit passage of light through said hole when said interface is coupled to said display panel.
4. The apparatus as recited in claim **1** wherein said one or more compliant bumps are located to be adaptable for interfacing with said pads on two sides of display panel.
5. The apparatus as recited in claim **1** wherein said one or more compliant bumps are located to be adaptable for interfacing with said pads on four sides of said display panel.
6. The apparatus as recited in claim **1**, wherein the one or more compliant bumps are compressible.
7. A method for testing a display panel at various stages of manufacture comprising the steps of:
 - providing an interface having compliant bumps mounted thereon and electrical paths connected to said compliant bumps;

5

providing test circuitry operable for performing one or more test operations on said display panel, wherein said test circuitry is connected to said electrical paths;

mounting said interface onto said display panel so that said compliant bumps make contact with pads on said display panel, wherein said pads are electrically connected to pixel locations on said display panel.

8. The method as recited in claim 7, further comprising the step of:

pressing said interface toward said display panel so that all of said compliant bumps make contact with said pads, wherein said pressing step compresses one or more of said compliant bumps.

9. The method as recited in claim 7, wherein said display panel is in an intermediate stage of being manufactured.

10. The method as recited in claim 7, wherein said interface is a PCB.

11. The method as recited in claim 10, wherein said test circuitry includes driver electronics mounted on said PCB and coupled to said electrical paths.

12. The method as recited in claim 7, wherein one or more of said compliant bumps include a film of probing material.

13. The method as recited in claim 12, wherein said probing material includes a diamond grit.

14. The method as recited in claim 7, wherein the compliant bumps are compressible.

15. An apparatus adaptable for testing a display panel comprising:

6

an interface having electrical paths adaptable for coupling to display test circuitry; and

one or more compliant bumps mounted on said interface and connected to said electrical paths, wherein said one or more compliant bumps are adaptable for making contact with pads on said display panel.

16. The apparatus as recited in claim 15, wherein said interface is a PCB.

17. The apparatus as recited in claim 16, wherein said display test circuitry includes driver electronics mounted on said PCB and coupled to said electrical paths.

18. The apparatus as recited in claim 15, wherein said interface has a ring structure forming a hole in said interface to permit passage of light through said hole when said interface is coupled to said display panel.

19. The apparatus as recited in claim 15, wherein said one or more compliant bumps are located to be adaptable for interfacing with said pads on two sides of said display panel.

20. The apparatus as recited in claim 15, wherein one or more of said compliant bumps include a film of probing material.

21. The apparatus as recited in claim 20, wherein said probing material includes a diamond grit.

22. The apparatus as recited in claim 15, wherein the one or more compliant bumps are compressible.

* * * * *